

APPLICATION:  
 JOB NAME:  
 QUANTITY:                      ITEM NO.

PRODUCT NAME:  
 PRESSURE VACUUM BREAKER  
 ANTI-SPILL WALL MOUNT

\_\_\_\_\_ SPECIAL CONFIGURATION  
 CHECK BASE MODEL AND OPTIONS

MODEL:  
 ■ 14540

OPTIONS OR MODIFICATIONS:  
 OTHER \_\_\_\_\_

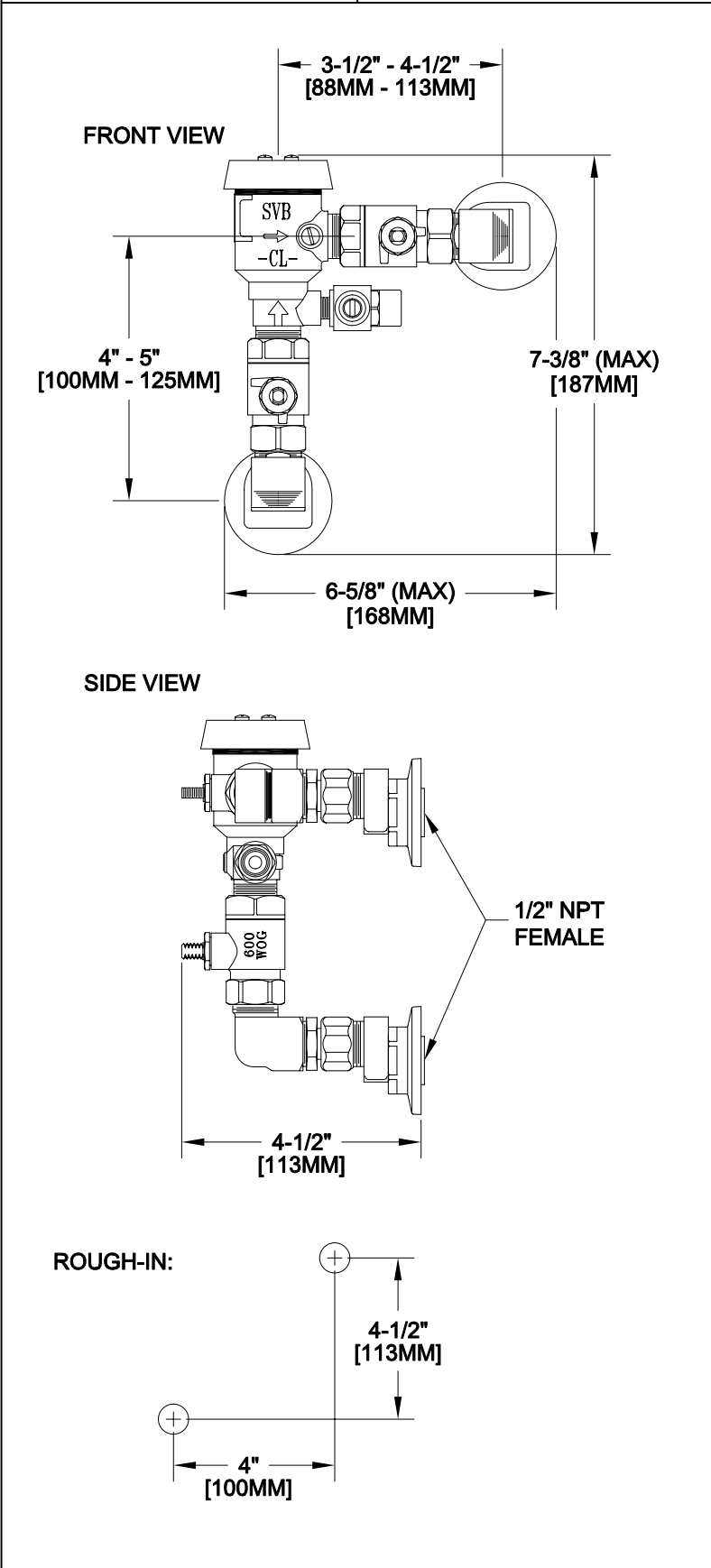

**FEATURES**

- \* SPILL RESISTANT
- \* ASSE - 1056 APPROVED
- \* 1/2" NPT FEMALE INLET AND OUTLET

**SYSTEM LIMITS**

- \* TEMP: 33°F MIN. TO 180°F MAX.
- \* PRESSURE: 150 PSI MAX. STATIC

**SHIPPING WEIGHT**

- \* 4.0 LBS

ANSI/A112.18.1M

**FISHER**  
 FISHER MANUFACTURING COMPANY  
 TOLL FREE: 800-421-6162 - FAX: 800-832-8238  
 information@fisher-mfg.com - www.fisher-mfg.com